

THIS DRAWING IS UNPUBLISHED. RELEASED FOR PUBLICATION
 © COPYRIGHT - By - ALL RIGHTS RESERVED.

LOC		DIST		REVISIONS			
P	LTR	DESCRIPTION		DATE	DWN	APVD	
CM	00	G		REVISED PER ECR-13-008204	10DEC2013	KH	TM

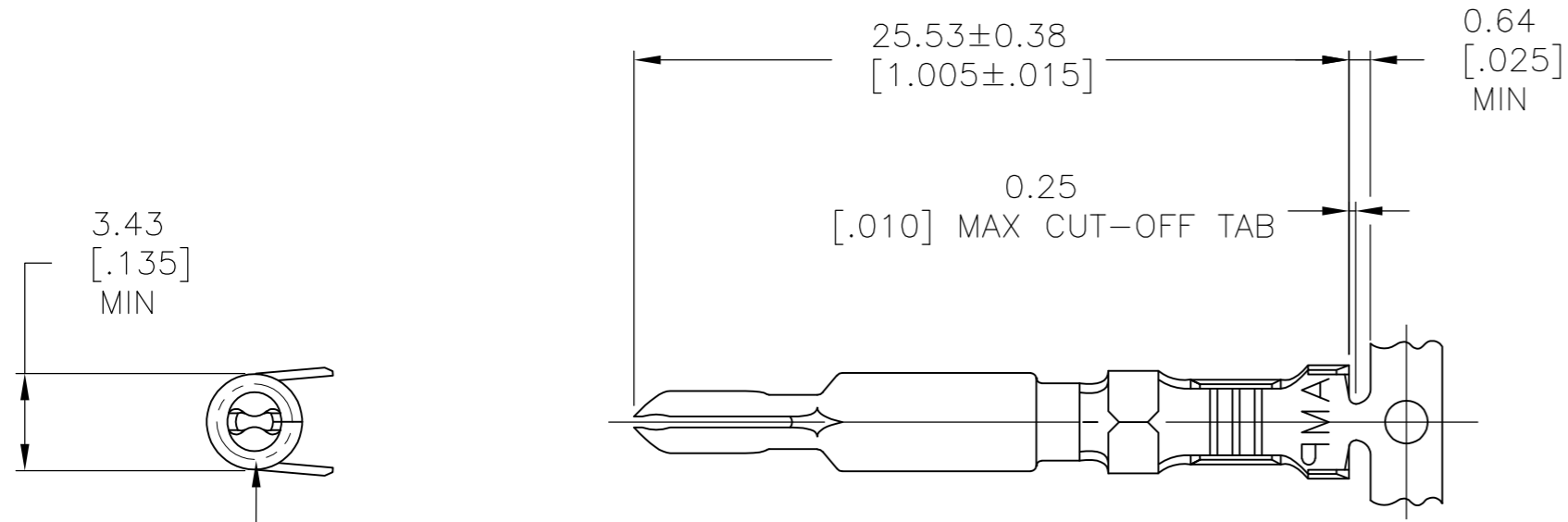

SEE DETAIL A

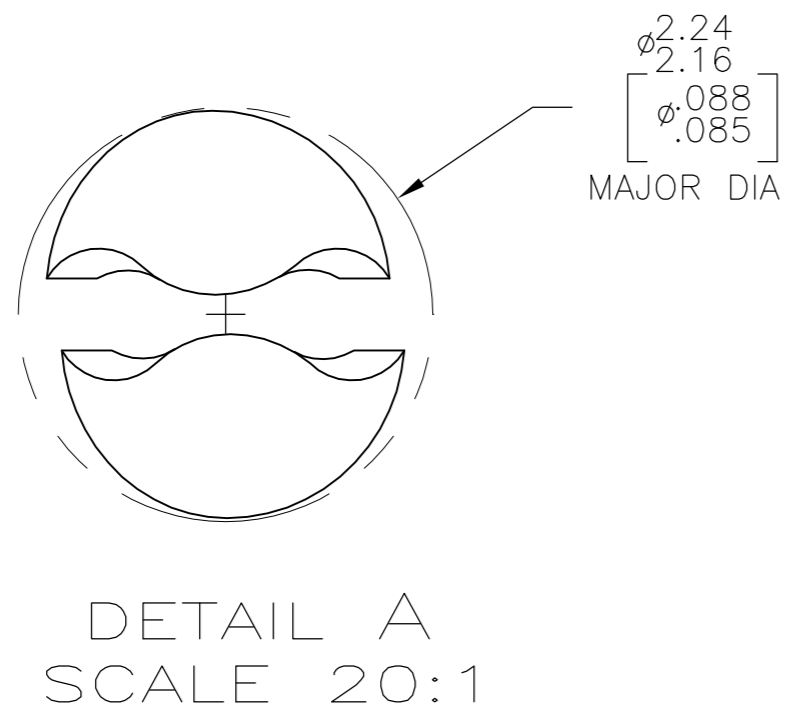
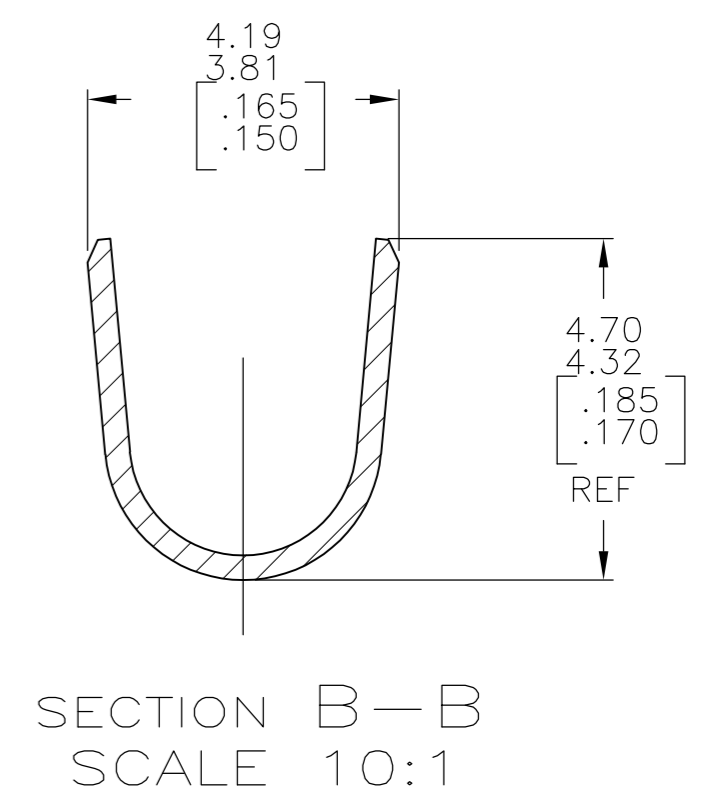
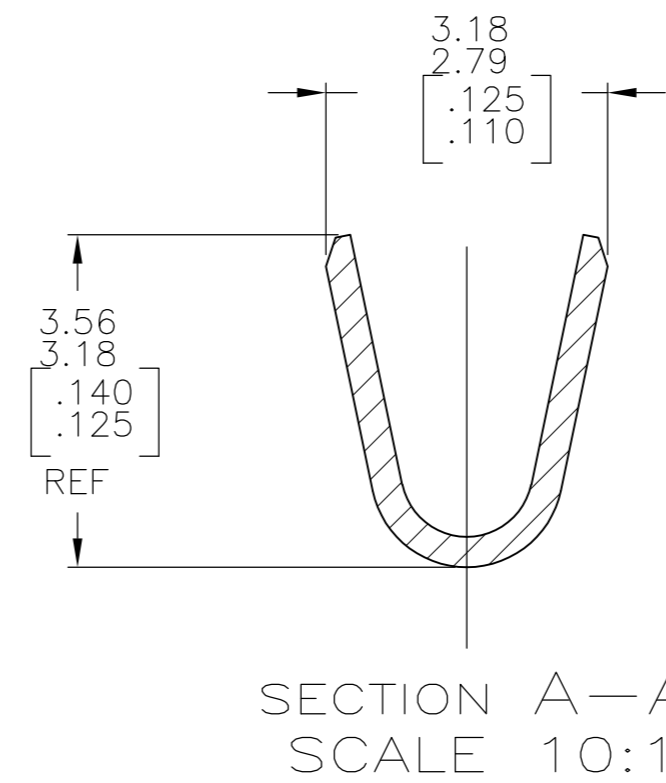
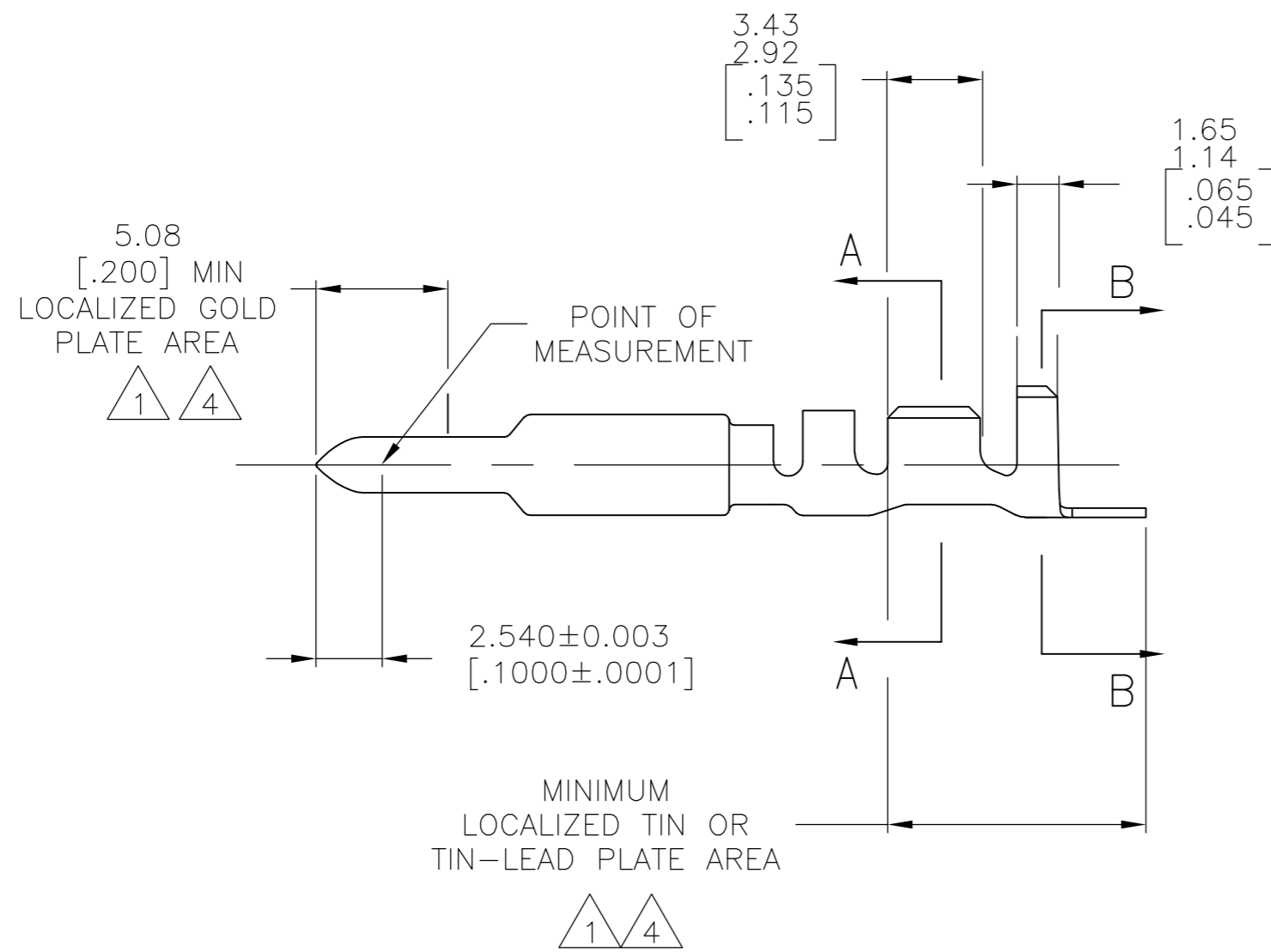

- 1 0.00076[.000030] MIN GOLD AT POINT OF MEASUREMENT IN THE LOCALIZED GOLD PLATE AREA, 0.00127[.000050] MIN TIN-LEAD IN TIN-LEAD PLATE AREA, 0.00127[.000050] MIN NICKEL UNDERPLATE ON ENTIRE CONTACT.
- 2 WIRE RANGE: 0.5-2mm² [20-14 AWG] INSULATION RANGE: 1.52-3.30 [.060-.130] DIA.
- 3 DIMENSIONS IN BRACKETS ARE IN INCHES.
- 4 0.00076[.000030] MIN GOLD AT POINT OF MEASUREMENT IN THE LOCALIZED GOLD PLATE AREA, 0.00127[.000050] MIN TIN IN TIN PLATE AREA, 0.00127[.000050] MIN NICKEL UNDERPLATE ON ENTIRE CONTACT.
- 5 SUPERSEDED BY 1-770007-0

5	GOLD	4	0.30 [.012]	BRASS	1-770007-0
	GOLD	1	0.30 [.012]	BRASS	-770007-2-
	PRE-TIN		0.30 [.012]	BRASS	770007-1
	FINISH			MATERIAL	PART NUMBER

THIS DRAWING IS A CONTROLLED DOCUMENT.		DWN	S. CARPENTER	20MAY03	STE TE Connectivity	
DIMENSIONS: mm [INCHES]		CHK	C. JONES	20MAY03		
TOLERANCES UNLESS OTHERWISE SPECIFIED:		APVD	C. JONES	20MAY03	NAME	
0 PLC	± -	PRODUCT SPEC	PIN, UNIVERSAL MATE-N-LOK(TM) II			
1 PLC	± -	APPLICATION SPEC	SIZE CAGE CODE DRAWING NO RESTRICTED TO			
2 PLC	± -	WEIGHT	A2 00779 C=770007			
3 PLC	± -	CUSTOMER DRAWING	SCALE 4:1 SHEET 1 OF 1 REV G			
4 PLC	± -					
ANGLES	± -					
FINISH	SEE TABLE					